

WITLEY MOTOR CYCLE CLUB

Motorcycle sport since 1924

PROGRAMME

2012



WITLEY Classic ENDURO

Sunday 5th February 2012
Warren Heath, nr Blackbushe
A30/A327 - Yateley - Surrey/Hants border

1st Round South East Enduro Combine Championship 2012
Start 10.00am

www.witleymcc.org



Welcome

to the

Witley

CLASSIC ENDURO

at

Warren Heath, Yateley,
Hook, Hants.

Start Time 10.00am.

A.C.U. Permit No ACU34439



Clerk of the Course: Colin Boniface (21449)

Mobile: 07812 924510

Course Planners: *Robert Carey Arnoud Didey*

Secretary of the Meeting: Manuel Bernardez

Mobile: 07941477916

Club Stewards: Bill Glover, Bernard Jay

Technical Officials: Richard Troth & Nick Robinson

Chief Marshal: Phill Taylor 07831 784669



Remember
it's all about having fun



Bayliss Transport
Storage & Distribution



R. COLLARD
Demolish • Dispose • Recycle

SEEC 2012 Provisional Dates

5th February Witley Enduro, 2012 Enduro

26th February Surrey Police Enduro, 2012 Enduro

25th March Carshalton Hare & Hounds, 2012 H & H

22th April Normandy Hare & Hounds, 2012 H & H

29th April Kingston Enduro, 2012 Enduro

6th May LFB Sprint

20th May Croydon Enduro, 2012 Enduro

10th June Carshalton Enduro, 2012 Enduro

29th July Sidcup Enduro, 2012 Enduro

16th September Kingston Hare & Hounds, 2012 H & H

7th October Normandy Enduro, 2012 Enduro

13/14 October SEEC Enduro, 2012 BEC

28th October Sidcup Hare & Hounds, 2012 H & H

4th November LFB Hare & Hounds, 2012 H & H

25th November Surrey Police Hare & Hounds, 2012 H & H

1st December SEEC Awards Presentation Evening

27th December Witley Hare & Hounds, 2013 H & H



Today's official event photographers

www.teamsnapper.co.uk

FINAL INSTRUCTIONS

Please read *very* carefully...

VENUE: Florescent arrows of A30. The Welsh Drive, Hook, Hampshire, RG27 0QB

SIGNING ON:- 7:30am - 9:45am (Before Technical Control) **DON'T BE LATE!**

All riders to show current **ACU competition licence and club membership cards**, failure to do so will result in a **£10.00 one event licence** & Witley MCC, **Sorry!**

Riders under 18 MUST be accompanied by Parent or legal guardian to sign on.

TIMING: Electronically timed using transponders. Best practice is to gently touch the receiver rather frantic arm waving. **It is the responsibility of the rider to make sure every check is counted**, do not ride away until you see your number come up on the monitor, errors cannot be rectified later

Numbers:

Championship. Red plates front & sides with white numbers.

Expert. Green Plates front and side with white numbers

Clubman A & B Yellow plate front and side with black numbers.

Veteran A & B Blue plate front and side with white numbers.

Sportsman. Black plates front and sides with white numbers.

TECHNICAL CONTROL:- 8:00am - 9:45am, machine & helmet (Minimum Standard - Silver Approval ACU Stamp for Enduro).

You may start your bike and ride to the technical control if parked a distance away, engines should not be started for any other reason.

TYRES: Front tyre tread pattern optional, for all classes. Rear Tyres **MUST** be Road Legal Trial, Trail, or Enduro Tyres. With a tread depth not exceeding 13mm. Please see the current Handbook for clarification.

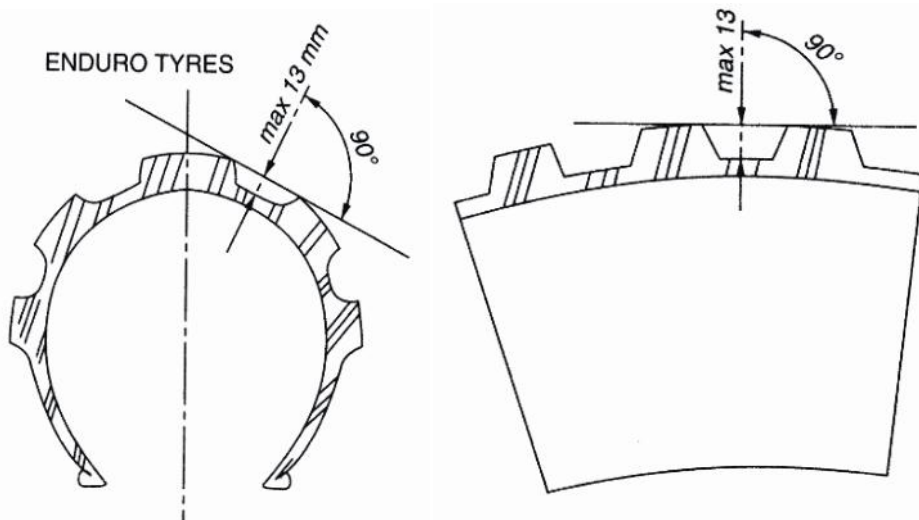

Championship

No.	Start	Name	Club	License	Machine
1	10:00	James Burroughs	Sidcup	50630	Freestyle Husqvarna WR 250
2	10:00	Matt Brown	Kingston	78584	Hotwheels KTM EXC 500
3	10:00	Dan Lawry	Kingston	79741	Teamsnapper KTM EXC 250
4	10:00	Jack Turner	Kingston	104045	The KTM Centre KTM EXC 250
5	10:01	Clive Gammage	Croydon	124548	KTM EXC 125
6	10:01	Phil Maltby	Castle	69788	KTM EXC 450
7	10:01	Rich Ely	Sidcup	26730	Edmondson Racing KTM XCF 250
8	10:01	Tony Williamson	Sidcup	74582	KTM XCF 250
9	10:02	Daniel Taylor	PMCRC	Day	KTM EXC 350

Expert

No.	Start	Name	Club	License	Machine
13	10:03	Malcolm Coles	Surrey Police	123624	Finch Cycles Yamaha YZ 125
14	10:03	Gareth Hughes	Kingston	134064	KTM EXC 250
15	10:03	Danny Andrews	Witley	108325	Husqvarna TE 310
16	10:03	Robert Taylor	Croydon	79349	KTM EXC 125
17	10:04	Mark Jordan	Kingston	59221	KTM XC 300
18	10:04	Dan Warner	Normandy	132228	LTL Racing TM EN 250
19	10:04	Steve Jose	Camel Vale	106475	Thor MC's Gas Gas RACING 250
20	10:04	Daniel Rose	Carshalton	135277	Central Bikes KTM EXC 300

Veteran A

No.	Start	Name	Club	License	Machine
25	10:06	Nick Dyer	Kingston	81341	Yamaha WRF 250
26	10:06	Euan Harrison	Croydon	18461	GGR, Teamsnapper Husaberg FE 550
27	10:06	Ian Mitchell	Croydon	25332	KTM EXC 250
28	10:06	Chris Stanger	Croydon	134680	Teamsnapper Husqvarna TXC 310
29	10:07	Joe Beard	Croydon	99939	KTM EXC 250
30	10:07	Martin Stenhouse	Croydon	26552	KTM EXC 500
31	10:07	Dan Goodwin	Sidcup	96372	KTM EXC 300
32	10:07	Steve O'Brien	Sidcup	119495	KTM EXC 350
33	10:08	Joe Searchfield	Witley	21727	Husqvarna TE 250
34	10:08	Alex Taylor	Witley	141469	tmukonline.net TM EN FI 250

WARNING

MOTORSPORT CAN BE DANGEROUS

Despite the organisers taking all reasonable precautions, unavoidable accidents can happen. Please comply with all instructions of marshals and notices and remain in permitted areas only.

THEY ARE CONCERNED WITH YOUR SAFETY

Clubman A

No.	Start	Name	Club	License	Machine
41	10:10	Dex Bayne-Powell	Sidcup	74584	KTM EXC 525
42	10:10	Matthew Hubbard	Sidcup	141465	KTM EXCF 250
43	10:10	Steve White	Sidcup	135365	Teamsnapper KTM EXC 250
44	10:10	Elliot Davies	Normandy	148705	KTM EXC 350
45	10:11	Phil Davies	Normandy	114711	KTM EXC 450
46	10:11	Dan Sopp	Kingston	114640	Teamsnapper KTM EXC 250
47	10:11	Jamie Moller	Croydon	132516	Gas Gas EC 200
48	10:11	Chris O'Grady	Croydon	110363	KTM EXC 250
49	10:12	James Smith	Kingston	116263	Teamsnapper KTM EXC 200
50	10:12	Richard Morgan	Croydon	127892	Teamsnapper KTM EXC-F 250
51	10:12	Dan Brundell	Kingston	111928	KTM EXC 300
52	10:12	Tristan Robinson	Witley	100133	Maxima Oils Gas Gas EC 125
53	10:13	John Brown	Witley	133137	KTM EXC 250
54	10:13	Joe Gordon	Kingston	98520	Massey Ferguson Gas Gas EC
55	10:13	Jim Ryan	Sidcup	140119	KTM EXC 450
56	10:13	Jack Ryan	Sidcup	Day	KTM EXC 300
57	10:14	David Machinek	Alton	81225	LRS Mec KTM EXC 300
58	10:14	Gary Hanson	Witley	134044	Husqvarna TE 310
59	10:14	Aaron Dibnah	Normandy	106560	Team Dibby Racing KTM XC 300
60	10:14	Marc Morley-Freer	Carshalton	101073	Gas Gas EC 300
61	10:15	Andrew De-Merist	Normandy	58170	Husqvarna TE 310
62	10:15	James De-Merist	Normandy	58320	Husqvarna WR 125
63	10:15	Thomas Sargent	DMCC	135914	KTM EXC-F 350
64	10:15	Richard Creedy	Witley	Day	KTM EXC 250
65	10:16	Lee Barthram	Sidcup	138318	KTM EXC 450
66	10:16	Andrew Wiseman	Sidcup	120016	Husqvarna TE 250
67	10:16	Tim Thurgood	Witley	Day	KTM EXC 300
68	10:16	Craig Kieck	Sidcup	149158	Suzuki RMX 450

Veteran B

No.	Start	Name	Club	License	Machine
73	10:18	Andy Brown	Croydon	83531	KTM XCF 250
74	10:18	Hans Gilham	Sidcup	53252	Team IF KTM EXC 500
75	10:18	Steven Wass	Witley	108985	Gas Gas EC 200
76	10:18	Peter Moller	Croydon	6708	Husaberg FE 450
77	10:19	Andrew Sharp	Sidcup	2830	KTM EXC-f 250
78	10:19	Colin Cowley	Croydon	5888	KTM EXC 500
79	10:19	Mark Jackson	Witley	day	Suzuki RMX 250
80	10:19	Peter Lawry	Kingston	20601	KTM EXC 200
81	10:20	Gary White	Witley	146703	KTM EXC 200

Veteran B continued ...

No.	Start	Name	Club	License	Machine
81	10:20	Gary White	Witley	146703	KTM EXC 200
82	10:20	Stephen Brooman	CSMA	30081	KTM EXC 250
83	10:20	Tony Wilde	Witley	145897	TM EN 144
84	10:20	Matthew Seare	Witley	90372	sewardcars.com Husqvarna TE 250
85	10:21	Richard Shaw	Witley	Day	KTM EXC-F 250
86	10:21	Roy Andrews	Witley	Day	Yamaha WRF 250
87	10:21	Paul Reich	Croydon	21448	KTM EXC 300
88	10:21	Graham Farquhar	Sidcup	1324710	Fast Eddy Suzuki RM 250
89	10:22	Andy Dean	Witley	21792	KTM EXC 200
90	10:22	Ian Mace	Witley	58287	KTM EXC 250
91	10:22	Andrew White	Witley	146663	Husqvarna WR 250
92	10:22	Brian Torr	TBEC	124842	KTM EXC-F 250
93	10:23	Kevin O'Reordan	Sidcup	88189	KTM SXF 250
94	10:23	Chris Edwards	Croydon	137250	KTM GAFFA 300
95	10:23	Nocholas Ford	Sidcup	Day	Husqvarna TE 250
96	10:23	Carl Mexter	Sidcup	Day	KTM EXCF 350
97	10:24	Carl Smye	Sidcup	95817	Gas Gas CC 250
98	10:24	Kevin Reid	LFB	Day	AG Lifts ,JCM Construction KTM EXC 250

Evo

No.	Start	Name	Club	License	Machine
101	10:25	Colin Fox	Croydon	135087	Kawasaki KDX 200

Clubman B

No.	Start	Name	Club	License	Machine
105	10:26	Ben Young	LFB	31543	SMD Off -Road KTM EXC 200
106	10:26	Martin Biles	LFB	75988	P&K HeatingHonda CFR-X 250
107	10:26	Zade Alassad	LFB	22315	SMD Off-Road Husqvarna WR 125
108	10:26	Karl Dyderski	LFB	119619	Teamsnapper KTM EXC 300
109	10:27	Richard Jones	Normandy	108670	Gas Gas EC 300
110	10:27	Stephen Watton	Kingston	Day	KTM EXC 200
111	10:27	Matt Taylor	Sidcup	128764	KL Property Lawyers KTM EXC 250
112	10:27	Rob Mussell	Normandy	106643	Woods Butchers KTM XC 350
113	10:28	Mark Horswell	Kingston	134220	Honda 250
114	10:28	Shane Babey	PMCRC	86318	Babey Racing KTM EXC 300
115	10:28	Bob Hardwick	Kingston	127695	Honda CR 250
116	10:28	Dom Wilson	Witley	148872	Honda CRF-X 450
117	10:29	Myles Morley-Freer	Carshalton	Day	Gas Gas EC 200

Clubman B continued ..

No.	Start	Name	Club	License	Machine
117	10:29	Myles Morley-Freer	Carshalton	Day	Gas Gas EC 200
118	10:29	Paul Todd	Carshalton	82107	Honda CRF 250
119	10:29	Andy Marriner	Sidcup	Day	Teamsnapper KTM EXC 250
120	10:29	Keith Workman	Normandy	88003	KTM EXC-F 250
121	10:30	Sam Dimmock	Witley	140467	KTM EXC 350
122	10:30	Andrew Walshe	Hux	147287	KTM EXC 200
123	10:30	Lee Sims	Witley	Day	Gas Gas EC 300
124	10:30	Ben Lewis	Kingston	21111	Husqvarna TE 250
125	10:31	George Thompson	Surrey SB	115010	Gas Gas EC 250
126	10:31	Simon Brown	Normandy	119720	Woods Butchers Yamaha WRF 250
127	10:31	Dan Isard	Sidcup	147683	KTM EXC 250
128	10:31	Matt Isard	Sidcup	147682	KTM EXC 250
129	10:32	Allan Angold	Croydon	50115	KTM EXC 250
130	10:32	Robin Scarry	Kingston	28194	Honda CRF-X 250
131	10:32	Mick Scarry	Kingston	28179	Honda CRF-X 250
132	10:32	Peter Reid	Kingston	119319	KTM 450 EXC 450
133	10:33	Chris Welch	Witley	145944	C A Welch Engineering KTM EXC 300
134	10:33	Alexis Russell	Witley	28900	KTM EXC 300
135	10:33	Rick Gardner	Witley	148712	TDR KTM EXC 250
136	10:33	Vincent Austin	Witley	114411	KTM EXC 250
137	10:34	Lee Whitcombe	PMCRC	136253	KTM XC 250
138	10:34	Russ Johns	Kingston	20183	KTM EXC 300
139	10:34	Andrew Gilden	Normandy	122626	KTM EXC 200
140	10:34	Ian Hill	Kingston	86663	Gas Gas EC 250
141	10:35	Steve Haselden	Sidcup	135075	KTM EXC 250
142	10:35	Ashley Pitman	Witley	149380	KTM EXC F 250
143	10:35	Mark Brincat	PMCRC	148545	KTM EXC 200
144	10:35	Laurence Leahy	PMCRC	Day	KTM EXC 300
145	10:36	Thomas Soanes	Sidcup	Day	Gas Gas EC 250
146	10:36	James Fowler	Witley	148539	Husqvarna TE 250
147	10:36	James Coneron	Witley	149590	KTM EXC 200
148	10:36	Barney Thurgood	Witley	Day	KTM EXC 125
149	10:37	David Collado	LFB	148908	Yamaha WRF 450
150	10:37	Michael Geurts	South Reading	Day	KTM EXC 200
151	10:37	Ian Nicholls	Sidcup	Day	KTM EXC 450
152	10:37	Daniel Simpson	Sidcup	Day	KTM EXCF 250

Sportsman

No.	Start	Name	Club	License	Machine
153	10:38	Jon Casey	Normandy	98391	KTM EXC 200
154	10:38	Ian Scott	Witley	97201	KTM EXC 300
155	10:38	Andy Scott	Witley	137057	Honda CRFX 450
156	10:38	Sebastian Chilvers	PMCRC	Day	Gas Gas EC 300
157	10:39	Jarrold Pearson	Witley	97829	Husqvarna CR 125
158	10:39	Gavin Terry	Croydon	142450	KTM EXC 200
159	10:39	Daniel Lucas	Witley	149082	Honda CRF 250
160	10:39	Philip Hopkins	Witley	Day	Honda CRM 250
161	10:40	Andy Green	Witley	Day	Yamaha WR 400
162	10:40	Tom Wells	Carshalton	Day	KTM EXC 450
163	10:40	Luke MacRae	Witley	Day	KTM EXC 450
164	10:40	Oliver MacRae	Witley	Day	Yamaha WR 250
165	10:41	Rob Giles	Sidcup	117003	Gas Gas EC 200
166	10:41	Alan Taylor	Kingston	142331	Yamaha WRF 250
167	10:41	John Jewell	Witley	Day	Yamaha WRF 425
168	10:41	Paul Jakeway	Witley	146466	TM Enduro 250
169	10:42	Neil Hunt	Carshalton	Day	Honda CRF-X 450
170	10:42	Keith Fielder	Kingston	134232	KTM ECX 300
171	10:42	Kyle Creedy	Witley	Day	KTM EXC 200
172	10:42	Sue Wass	Witley	124374	Yamaha WR 250
173	10:43	Greg Wheeler	Witley	Day	Husqvarna TE 250
174	10:43	Nick Chapman	Witley	Day	Honda CRF 250
175	10:43	Ian Wales	Witley	Day	Yamaha WRF 250
176	10:43	Andy Church	Witley	Day	Kings Cross Scooters Yamaha WR 450
177	10:44	Daniel Weight	Hampshire	Day	Teamsnapper Yamaha YZ 250
178	10:44	Sean Trask	Hampshire	Day	Teamsnapper Husaberg TE 250
179	10:44	Shaun Hayward	Normandy	Day	KTM EXC 250
180	10:44	Daren Mason	Witley	134128	Honda CRF-X 250
181	10:45	Lee Snelling	Witley	Day	Honda CRF-X 250
182	10:45	Richard Alder	Witley	146009	Alders Automotive Yamaha WRF 250
183	10:45	Adrian Wicks	Sudbury	Day	KTM 250
184	10:45	Paul Carden	Sudbury	Day	Husqvarna TE 250
185	10:46	Gary Goble	PMCRC	149051	Teamsnapper Husaberg TE 300
186	10:46	Steve Fulcher	Sudbury	Day	Husqvarna TE 310
187	10:46	Paul Cosgrove	Kingston	88325	Gas Gas 200
188	10:46	Tucker Dow	Sudbury	Day	KTM EXCF 350
189	10:47	Jonathan Starkey	Witley	147253	KTM EXCF 250
190	10:47	Martyn Gale	Witley	144291	KTM EXC 300

The Rules

SOUND CONTROL:- Machines must be within the noise levels currently in force for that category of machine (see ACU Handbook)). Any rider losing a silencer or baffle or creating unacceptable noise will be sent to the pits to rectify it. The machine must then be inspected by the Technical Official prior to being allowed back on the course.

COURSE:- We hope to achieve a minimum length of up to 10 kms. The course will be marked by Florescent arrows, tape and route check gates which riders must pass through.

BLUE TAPE AREAS:- Areas defined with Blue Tape are for the protection of Officials and Marshals. They **MUST** be ridden at **WALKING PACE**. A 60 second **STOP - GO** penalty may be enforced for the first offence. Exclusion will be the result of a second offence.

FUEL:- Refuelling must take place in the designated **GREEN** area only. This will be defined by **GREEN SINAGE**. Each rider is responsible for their own fire precautions and should be equipped with the standard 2kg Dry Powder Extinguisher.

BREAKDOWNS:- It is the riders responsibility to recover his own machine.

**NO MACHINES TO BE STARTED OR RIDDEN
BEFORE THE START OF THE EVENT!**

START:- Cold engine start at 4 riders per minute intervals, failure to cross the green flags within 1 minute from start time 60 points.

WARNING

MOTORSPORT CAN BE DANGEROUS

Despite the organisers taking all reasonable precautions, unavoidable accidents can happen.

Please comply with all instructions of marshals and notices and remain in permitted areas only.

**THEY ARE CONCERNED WITH YOUR
SAFETY**

EXCLUSIONS

- Not riding at walking pace in the [BLUE tape area](#).
- Smoking in the refuelling area.
- Refuelling outside designated area.
- Not keeping to the course/Course cutting.
- Irregularities in lap times recorded, suggesting course cutting.
- Failure to keep any support crew member out of prohibited areas (i.e. punch check).

ACKNOWLEDGEMENTS

Forestry Commission England.

Rich & Erika Teamsnapper www.teamsnapper.co.uk

Rob Collard www.rcollard.com

David Bayliss www.baylisstransport.co.uk

K.R.M.B.S Medical Services.

SITE-EQUIP LTD Toilets

HOLLYWOOD DINER Calvert's Catering.

Club members and friends without whose help, this event would not be possible.





www.witleymcc.org

© 2010 WITLEY & DISTRICT MOTORCYCLE CLUB A Company limited by guarantee Registered at Cardiff.
Company Registration No. 05654047 Registered Office: 43 Orchard Close, Normandy, Surrey GU3 2EY